

General technical information on electromagnetic clutches and brakes

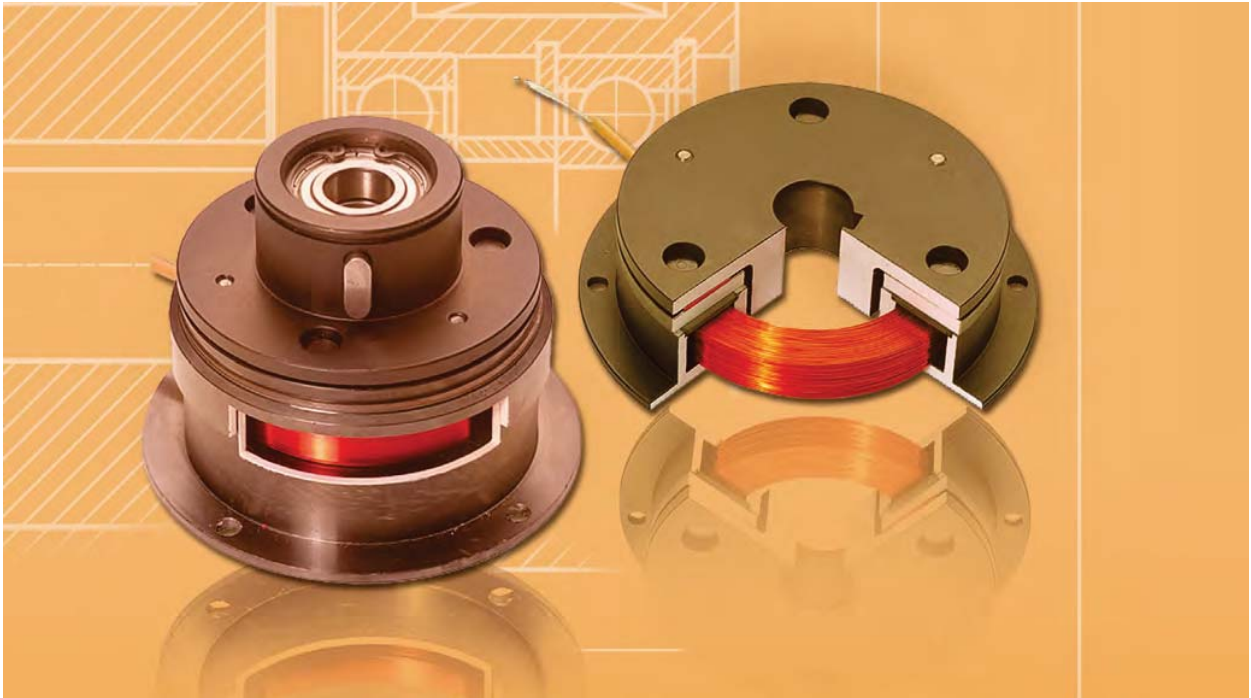

How do electromagnetic clutches or brakes work?

The working principles of electromagnetic clutches and brakes are very similar.

Electromagnetic clutches:

The stator body ① contains the field coil ②, which is a copper coil cast in synthetic resin. The clutch is activated by applying a direct current to the field coil. This creates a magnetic field, which electromagnetically attracts the armature plate ④ towards the input drive hub ⑦ with its friction lining ③, and so allows torque to be transmitted from the input side to the output.

The axially-located output drive hub ⑥ separates from the input side when the current is cut off. A return spring ⑤ ensures that the armature plate separates from the input hub.

Electromagnetic brakes:

The stator body ① contains the field coil ②, which is a copper coil cast in synthetic resin. When current is applied a magnetic field is created, which attracts the armature plate ④ towards the friction lining ③, and so transmits a braking torque to the output hub ⑥.

When the current is off, the return spring pulls the armature plate back to its original position.

SUCO is your perfect partner when you require a specifically fitted design for an electromagnetic clutch or brake, which matches perfectly with your application and design needs.

As SUCO manufactures electromagnetic as well as centrifugal clutches and brakes, we can even combine the two principles to provide you with a solution which uses the advantages of both technologies.

You will find these special solutions starting from page 39.

Typical applications

Among many other applications, SUCO electromagnetic clutches and brakes are used in construction machines, agricultural machinery, machine tools, pumps and compressors, centrifuges, belt conveyors and cleaning machines.

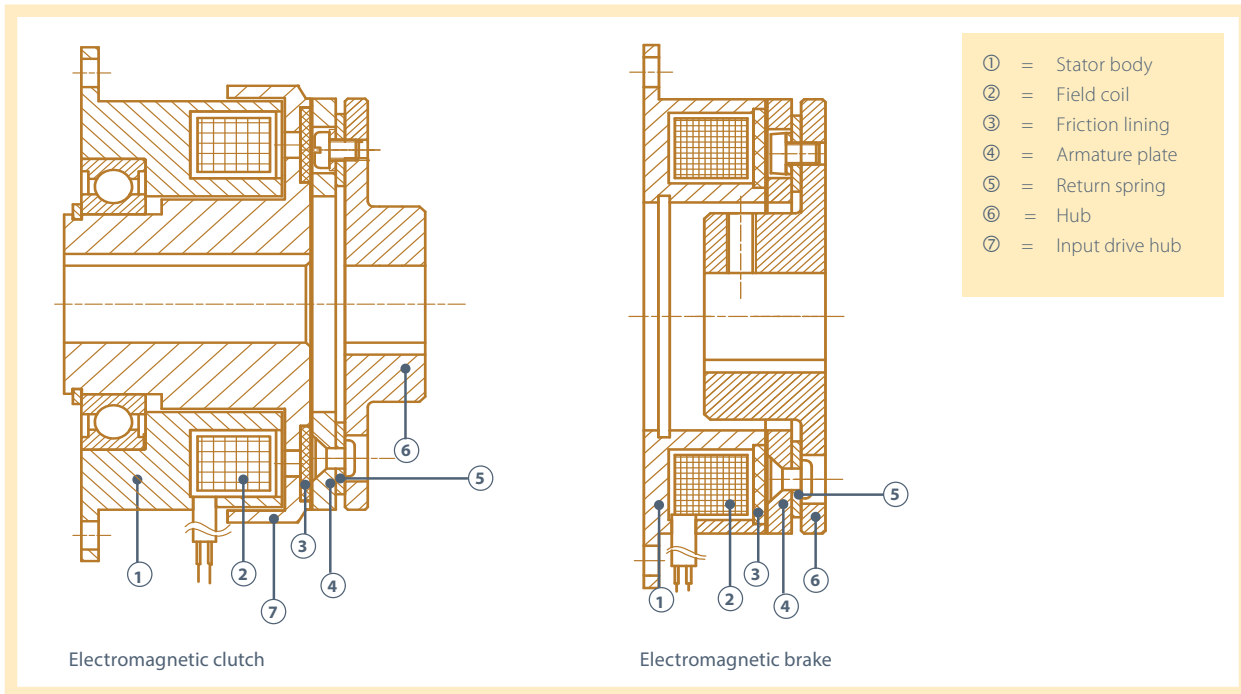

Construction and mode of operation of a electromagnetic clutch /brake

Technical explanations and important installation notes:

When SUCO electromagnetic clutches and brakes are correctly selected, they are trouble-free, require no maintenance, and are extremely reliable.

SUCO clutches are dry-running clutches. To ensure correct operation, grease and oil must be kept away from the clutches' and brakes' friction surfaces.

Electromagnetic clutches and brakes require a DC power supply. They normally operate on a 24 VDC supply, but can also be supplied for other voltages (6, 12, 48 and 190 VDC). As standard the power supply is via a 2-core cable 0.4 m long.

All SUCO clutches and brakes are normally open.

Depending on the size of a clutch or a brake, the installation must provide for an air gap of between 0.2 and 0.5 mm between the drive hub and the armature plate. The purpose of this air gap is to ensure complete separation of the input and output drives when no current is applied.

SUCO electromagnetic clutches and brakes can be installed on flanges or shafts. Flange-mounted versions require a suitable flange surface. The magnet component of the shaft-mounted models must be secured against rotation, the torque support must not be rigidly fixed.

If a SUCO output drive is not used, it is important to ensure that there are clearance holes to accommodate the rivet heads when installing the armature plate.

The armature plate is centred by the screws which hold the return spring to the output component. When the armature plate is installed, it must remain free to move axially against the return spring.

The standard form of output is an axial drive with a bore and keyway, which passes through a flange. On the subsequent pages also other variants are shown.

Electromagnetic clutch without bearing

Construction and mode of operation

When assembling, the stator must be accurately centred on the input drive hub, otherwise the hub may rub on the stator body and cause damage to the clutch. For further installation advises and technical details, please refer to page 28.

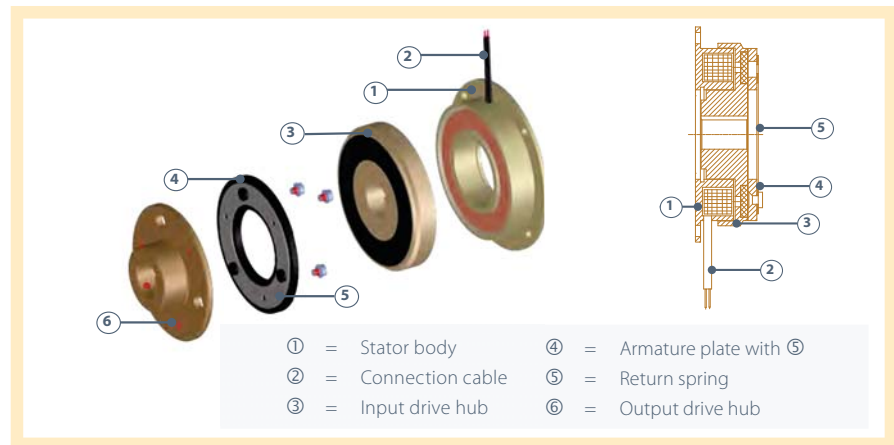

Model A

Clutch with input drive hub

Basic version without output drive hub. Connection to output side by screws.

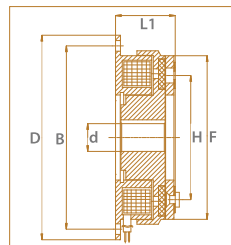

Model C

Clutch with input & output drive hub

Basic version with axial output drive (shaft - shaft).

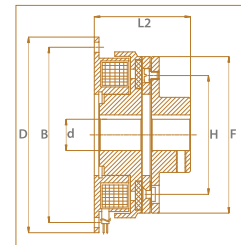

Performance data and dimensions

Size	E02	E03	E04	E05	E06	E07	E08	E09
Torque [Nm] For reference purposes ¹⁾	1.0	4.5	8.0	20.0	38.0	80.0	150.0	280.0
Speed of rotation max. [rpm]	10.000	8.000	6.000	5.000	4.000	3.000	3.000	2.000
Power [W] T = 20° C	9	12	20	23	32	40	55	72
d max. [mm] ²⁾	10	20	25	30	40	50	70	80
D [mm]	60	80	100	125	150	190	230	290
L1 [mm]	26.5	28.0	31.0	36.0	40.5	46.5	55.4	64.0
L2 [mm]	38.5	43.0	51.0	61.0	70.5	84.5	103.0	119.0
B [mm]	52	72	90	112	137	175	215	270
F [mm]	42	63	80	100	125	160	200	250
H [mm]	29	46	60	76	95	120	158	210

¹⁾ Depending on design of installation, operating and ambient conditions

²⁾ Keyway to DIN 6885/1

Electromagnetic clutch with bearing

G-Type

Construction and mode of operation

Due to the containing bearing, the stator body does not have to be centred on the input drive.
For further installation advises and technical details, please refer to page 28.

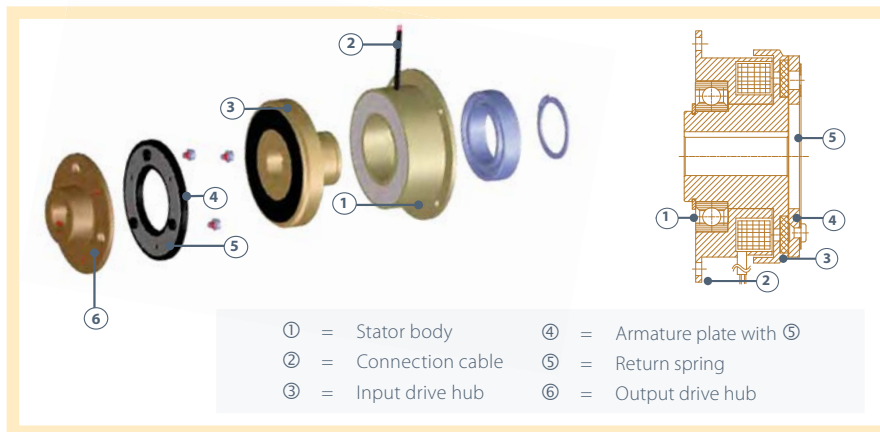

Model A

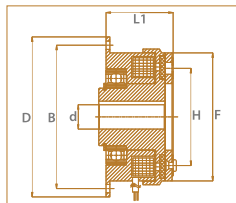

Clutch with input drive hub

Basic version without output drive hub. Connection to output side by screws.

Model C

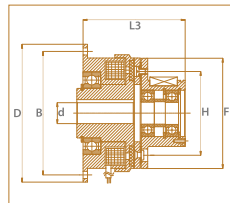

Clutch with input and output drive hub

Basic version with axial output drive (mounted on one shaft). Output drive hub with bearings.

Model D

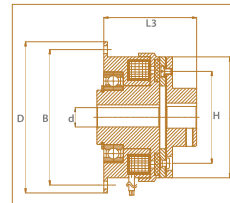

Clutch with input & output drive hub

Basic version with axial output drive (shaft - shaft).

Performance data and dimensions

Size	G03	G04	G05	G06	G07	G08	G09
Torque [Nm] For reference purposes ¹⁾	4.5	8.0	20.0	38.0	80.0	150.0	280.0
Speed of rotation max. [rpm]	8.000	6.000	5.000	4.000	3.000	3.000	2.000
Power [W] T = 20° C	12	20	23	32	40	55	72
d max. [mm] ²⁾	20	25	30	40	50	70	80
D [mm]	80	100	125	150	190	230	290
L1 [mm]	41.0	45.0	52.0	56.5	67.0	75.4	90.0
L2 [mm]	68.0	72.5	92.0	102.5	112.0	130.5	153.0
L3 [mm]	56.0	65.0	77.0	86.5	105.0	123.4	145.0
B [mm]	72	90	112	137	175	215	270
F [mm]	63	80	100	125	160	200	250
H [mm]	46	60	76	95	120	158	210

¹⁾ Depending on design of installation, operating and ambient conditions

²⁾ Keyway to DIN 6885/1

Electromagnetic brakes

Construction and mode of operation

The stator body must be installed concentrically with the output side. For further installation advises and technical details, please refer to page 28.

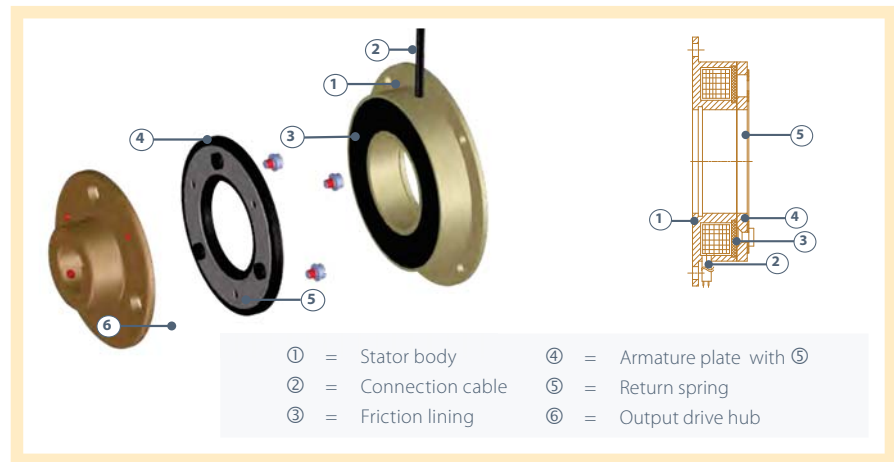

Model A

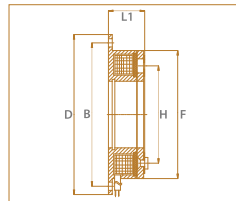

Brake without hub
Basic version without drive hub.
Connection to output side by screws.

Model B

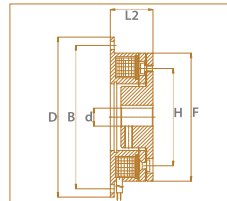

Brake with internal hub
Basic version with axial output drive. Internal hub.

Model C

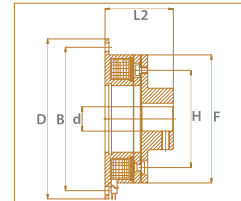

Brake with external hub
Basic version with axial output drive. External hub.

Performance data and dimensions

Size	B02	B03	B04	B05	B06	B07	B08	B09
Torque [Nm] For reference purposes ¹⁾	1.0	4.5	8.0	20.0	38.0	80.0	150.0	280.0
Speed of rotation max. [rpm]	10.000	8.000	6.000	5.000	4.000	3.000	3.000	2.000
Power [W] T = 20° C	9	12	20	23	32	40	55	72
d max. [mm] ²⁾	8	17	20	30	35	42	50	75
D [mm]	60	80	100	125	150	190	230	290
L1 [mm]	21.0	22.0	24.5	28.0	31.0	35.0	41.5	48.0
L2 [mm]	24.0	25.5	28.5	33.0	37.5	42.0	50.4	59.0
L3 [mm]	33.0	37.0	44.5	53.0	61.0	73.0	89.5	103.0
B [mm]	52	72	90	112	137	175	215	270
F [mm]	42	63	80	100	125	160	200	250
H [mm]	29	46	60	76	95	120	158	210

¹⁾ Depending on design of installation, operating and ambient conditions

²⁾ Keyway to DIN 6885/1

Key to model codes

Type designation:

E - Type
G - Type
B - Type

Size:

See table
 "Performance data
 and dimensions" on
 pages 29-31

Model:

A
B
C
D

Voltage:

A - 6 VDC
B - 12 VDC
C - 24 VDC
D - 48 VDC
G - 190 VDC

E **02** **A** **C** **08** **00** - **XXX**

BORE DIA. INPUT DRIVE HUB

Important!
 The number is a code,
 not the diameter.

BORE DIA. OUTPUT DRIVE HUB

Important!
 The number is a code,
 not the diameter.

**Consecutive
 number**

Different solutions, driven-side

To accommodate the variety of transmission requirements, SUCO offers a wide and modular product range. Special customized versions are available on request.

Clutch-brake combination (L-Type)

This model can be manufactured on request in the standard sizes. For performance data and dimensions, see E-Type (page 30) and B-Type (page 32).

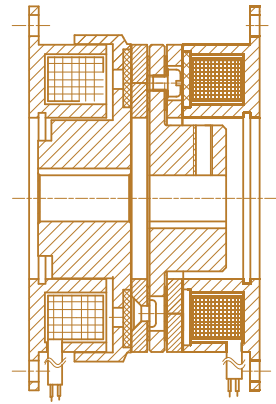

Figure 1

With bearing-supported flange

A flange supported on a hollow shaft and bearings is used for the output side connection.

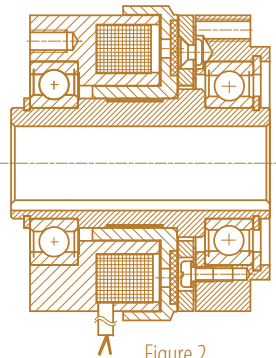

Figure 2

With a flexible coupling

If an axial or angular misalignment is to be expected between two shafts, a flexible coupling can be attached.

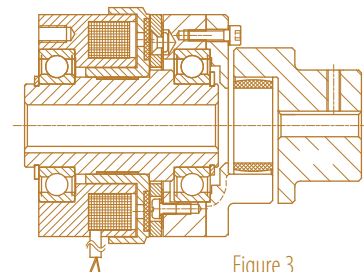

Figure 3

With bearing-supported belt pulley

The output drive is a single-groove belt pulley which is supported on a hollow shaft.

The pitch diameter can be supplied to the customers' requirements. Multiple-groove pulleys can also be supplied.

Common groove forms are: SPA, SPB, SPZ, and Poly-V or DIN/EN.

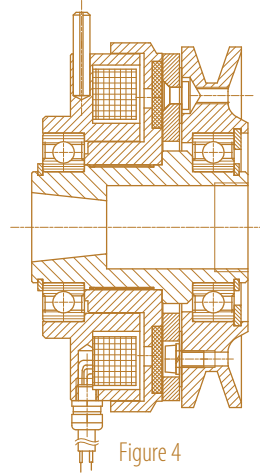

Figure 4

With belt pulley supported on separate bearings

Here the output drive is a single or multiple groove belt pulley which is separately supported, not on the hollow shaft of the electromagnetic clutch.

The pitch diameter of the pulley can be supplied to the customers' requirements.

Common groove forms are: SPA, SPB, SPZ, or Poly-V or DIN/EN.

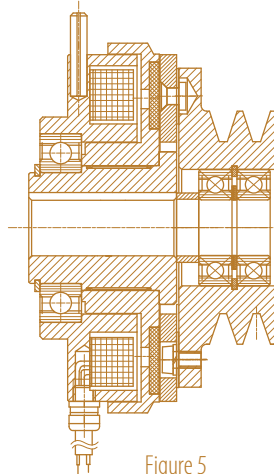

Figure 5

With sprockets

A chain sprocket mounted on a bearing supported flange transmits torque on the output side.

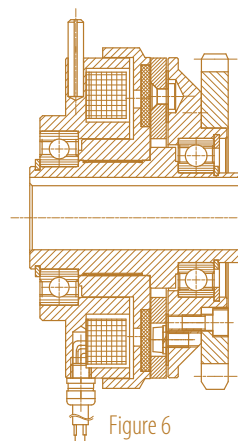

Figure 6