

esi

PROTRAN® PR9000

Heavy Duty Pressure Transmitter

- Silicon-on-Sapphire sensor technology for outstanding performance and reliability
- Pressure ranges up to 1,500 bar
- All stainless steel, robust construction for harsh environments
- Wetted parts in various materials
- ATEX/IECEx option available, including M1 for mining applications



The advanced sensor design consists of a piezoresistive silicon strain gauge circuit, which is epitaxially grown onto the surface of a sapphire diaphragm to form a single crystalline structure. The sapphire sensor element is then molecularly bonded to a titanium alloy sub-diaphragm.

This enables the sensor to endure higher over-pressures and provides superb corrosion resistance. The sensor exhibits virtually no hysteresis and excellent long-term stability over wide temperature ranges.

Specifications

The **PROTRAN© PR9000** Series pressure transmitters have been designed to meet the requirements of the majority of demanding industrial and process applications for pressure measurement requiring an output of 4-20 mA. With robust stainless steel housing construction, this range of pressure transmitters incorporates the latest Silicon- on-Sapphire strain gauge technology, together with a custom design amplifier offering excellent stability and accuracy over a long service life.

An important feature of this transmitter is the easily accessible screw terminal connections and the zero/span potentiometers conveniently positioned inside the screw cover head for simplified on-site adjustment and installation.

An optional ATEX and IECEx approved version of this product is available for explosion protection for flammable gases (zone 0), dusts (zone 20) and mining areas (group I M1).

Typical applications for include:

- mechanical and civil engineering
- process plant
- production test facility
- water resource
- power generation installations
- any fluid or gas application requiring stable, repeatable and accurate pressure measurement.



Dimensions (in mm)

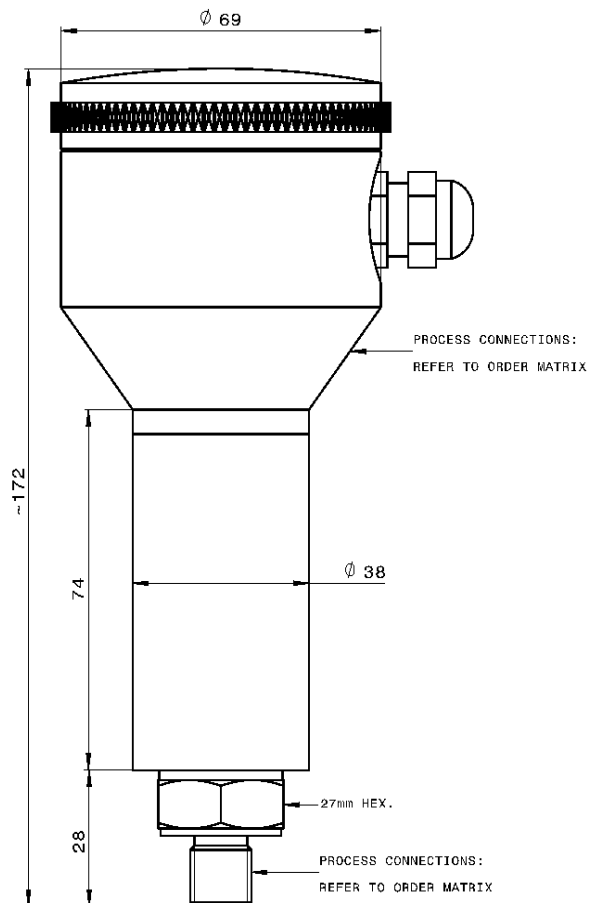

Electrical Connection

Pin No.	2 wire
1	+supply
2	4-20mA signal
3	N/C

Technical Data

Type	PR9000
Sensor Technology:	Silicon-on-Sapphire (ranges>1bar)/ Isolated Piezoresistive Silicon (ranges<1bar)
Output Signal:	4-20 mA (2 wire)
Supply Voltage:	13-36 VDC
Pressure Reference:	Gauge
Protection of Supply Voltage:	Protected against supply voltage reversal up to 50 V
Standard Pressure Ranges (bar):	0 – 1 bar Vac; 0 – 500 mbar; 0 – 1 bar; 0 – 10 bar; 0 – 25 bar; 0 – 100 bar; 0 – 250 bar; 0 – 700 bar; 0 – 1500 bar (Other options available)
Standard Pressure Ranges (psi):	0-30 in Hg; 0-7.5 psi; 0-15psi; 0-300psi; 0-1500psi; 0-3000psi; 0-10000psi; 0-20000psi (other options available)
Overpressure Safety:	2x all ranges up to 600 bar; 1.5x for 1000 bar; 1.1x for 1500 bar
Load driving Capability:	4-20mA: $RL < [UB-13V] / 20 \text{ mA}$ (e.g. with supply voltage (UB of 36V, max load (RL) is 1150Ω)
Accuracy NLHR:	$\leq \pm 0.3 \%$ of span BFSL (Optional higher accuracy version $\leq \pm 0.15 \%$ of span BFSL available)
Zero Offset & Span Tolerance:	$\pm 0.5 \%$ FS at room temperature $\pm 5 \%$ FS (approx.) adjustment with easy access trimming potentiometers
Operating Ambient Temperature:	-20°C to +85°C (-4°F + 185°F)
Operating Media Temperature:	-20°C to +85°C (-4°F + 185°F)
Storage Temperature:	+5°C to +40°C (+41°F to +104°F) Recommended Best Practice
Temperature Effects:	$\leq \pm 1.5 \%$ FS total error band for -20°C to +70°C. Typical thermal zero and span coefficients +0.015 %FS/°C
ATEX/IECEX Approval:	EX II 1 G Ex ia IIC T4 Ga (Zone 0), Ex II 1 D Ex ia IIIC T135°C Da (Zone 20), Ex I M1 Ex ia Ma (group 1 M1)
ATEX/IECEX Safety Values:	Ui = 28 V / Li = 119mA / Pi = 0.65 W / Li = 0.1 μH / Ci = 74 nF. Temperature Range = -20°C to +70°C. Max. cable length = 85m
Electromagnetic Compatibility:	Emissions: EN61000-6-3; Immunity: EN61000-6-2; Certified: CE/UKCA Marked
Insulation Resistance:	>100MΩ @ 50 VDC
Response Time 10-90%:	1mS
Wetted Parts:	Ranges >10 bar; SAE 316 stainless steel and titanium alloy; Ranges ≤10 bar; SAE 316 stainless steel and Nitrile NBR O-ring
Pressure Media:	Ranges >10 bar; all fluids compatible with SAE 316 stainless steel and titanium alloy; Ranges ≤10 bar; all fluids compatible with SAE 316 stainless steel and Nitrile NBR O-ring
Pressure Connection:	1/2" BSP male (G1/2); 1/2" NPT male (other options available)
Electrical Connection:	Screw terminals for conductor sizes 0.2-2.0mm ² are located beneath the screw lid. Cable entry head is through an IP68 cable gland with compression seal for cable sizes 4-8mm. Optional M20 Conduit fitting is available.
Net. Weight (Kg):	1.3 kg

Order Matrix

Output	Type	Electrical Connector	Pressure Range	Process Connection
4-20 mA	PR9000			
Electrical Connections/Options				
Cable gland IP68		-		
ATEX/IECEX certified with DIN EN175301 plug and socket		EX		
Pressure Range in bar				
0-1 bar Vac			V001	
0-0.5 bar			00.5	
0-1 bar			0001	
0-10 bar			0010	
0-25 bar			0025	
0-100 bar			'0100	
0-250 bar			'0250	
0-700 bar			'0700	
0-1,500 bar			1500	
Process Connection:				
1/2" BSP male (G1/2)				AC
1/2" NPT male				AN

Order Number Example	PR9000EX0700AC
-----------------------------	----------------

For options not listed please contact the sales team

DISCLAIMER: ESI Technology Ltd operates a policy of continuous product development. We reserve the right to change specification without prior notice. All products manufactured by ESI Technology Ltd are calibrated using precision calibration equipment, traceable to national measurement standards.