

esi

GENSPEC® GD4200HUSB

Digital Pressure Transmitter for Hydrogen

- Compatible for use within Hydrogen based environments
- Sample rate software selection up to 1,000 Hz
- Silicon-on-Sapphire pressure sensor technology
- Pressure ranges from vacuum to 5,000 bar
- Free ESI-USB® downloadable software with auto update
- Measure & record up to 16 pressure inputs together
- Create customised test certificates
- Automatic temperature compensation
- Support for easy integration with applications created by C#, VB, Labview and Excel VBA (api dll library)
- 2m lead & carry case included



Materials used in the manufacture of the Hydrogen range have been tested based on ISO 11114-4:2017 in accordance to the European Regulations EC 79/2009 and EU 406/2010 to determine an "embrittlement index" of the material when placed in a saturated environment over an extended period of time.

Results have provided a Pass rating to the compatibility of the specialist Titanium Alloy of the range against Hydrogen.

Specifications

The **GENSPEC Dynamic GD4200HUSB** digital pressure transmitter offers reliable and accurate pressure measurement from vacuum to 5000 bar. It is specifically designed to measure, analyse and record pressure directly to your PC without the need of costly I/O interface board. The easy "plug and play" nature of the unit allows the user to easily download the free ESI-USB© software and view live pressure data in as little as 10 minutes.

The unique Silicon-on-Sapphire sensor technology provides outstanding performance and gives excellent stability over a wide temperature range. Excellent measurement accuracy provides high resolution with a precision greater than 1 in 10,000. Ten pressure ranges have been carefully selected to enable the user to cover any pressure that the application requires, from vacuum up to 5,000 bar, via the use of the ESIUSB© digitally self-scaling software.

Each unit is supplied with 2m USB lead (rated to IP68), and a convenient carry case.

Typical applications include:

- Test and Measurement
- Laboratory or process measurement
- Leak testing and continuous monitoring

Dimensions (in mm)

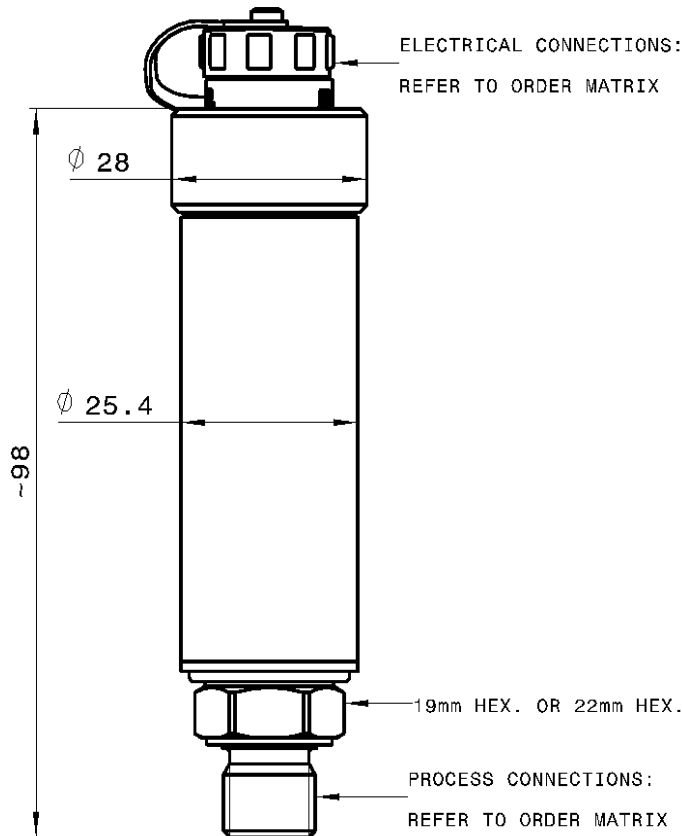

Electrical Connections
USB Mini B Socket
MIL-C-26482 (6-PIN)

Hex Size	Range/Thread
19mm	10 bar and above
22mm	Below 10 bar
	F250-C
	M16 HP

ESI-USB© Software

Data is presented on the PC via the ESI-USB© fully configurable Windows Interface software. It has instant connection with auto-detection, and will configure automatically with your desktop, laptop or Windows tablet via USB protocol. The sample rate enables dynamic pressures to be measured with up to 21 bit resolution at user selectable speeds up to 1,000 Hz.

For real-time analysis, data transferred to the PC is achieved without loss of accuracy or bandwidth. Compatible with computers with USB 2.0/3.x type A ports, the ESI-USB© interface configuration and analysis software runs on Windows 8, 10 and 11. Data can be displayed in graphical or tabular form, with a choice of pressure units and fully adjustable scales. Data can be saved to a file or exported to Excel/PDF.

The ESI-USB© software has many features including custom certificate generation, customisable certificate templates, leak testing, record and view up to 16 sensors at the same time, virtual differential pressure measurement, set automatic test start and stop times, and alarm levels for each individual sensor. Excellent measurement accuracy provides high resolution with a precision greater than 1 in 10,000.

Each unit requires free download of the ESI-USB© software and is supplied with 2m USB lead, with an option 4.5m lead also available.



Hydrogen Compatibility and Silicon-on-Sapphire

The ESI hydrogen pressure transmitters are turned from a special titanium alloy for the measuring cell and the wetted parts from a single piece of titanium. Thus the sensor is manufactured without seals, high pressure cells from 1000 bar are , which helps to avoid any weak points. This is especially important for the use with hydrogen due to the embrittling qualities of the media. Our materials have successfully passed the hydrogen compatibility testing based on ISO 11114-4:2017 in accordance with the European regulations EC 79/2009 and EU 406/2010.

The combination of titanium sensing elements with SOS sensors has a long tradition at ESI, this material choice allows the construction of a long term stable sensor that has a high accuracy. Our measurement ranges up to 5000 bar which makes this transmitter the preferred choice for use on hydrogen storage tanks and pipelines. An additional offer of the same technology for low pressures and also in vacuum measurement applications is also available.

Each Hydrogen approved unit also includes a certificate of conformity verifying Hydrogen compatibility.

The unique Silicon-on-Sapphire sensor technology provides outstanding performance and gives excellent stability over a wide temperature range. The advanced sensor design consists of a piezoresistive silicon strain gauge circuit, which is epitaxially grown onto the surface of a sapphire diaphragm to form a single crystalline structure.

The sapphire sensor element is then molecularly bonded to a titanium alloy sub-diaphragm. This enables the sensor to endure higher over- pressures and provides superb corrosion resistance. The sensor exhibits virtually no hysteresis and excellent long-term stability. With outstanding insulation properties, the sapphire substrate allows the sensor to operate over a very wide temperature range without loss of performance.



Technical Data

Type	GD4200HUSB	
Sensor Technology:	Silicon-on-Sapphire (SOS)	
Output Signal:	USB 2.0 compatible	
Supply Voltage:	5 Vdc via USB bus	
Pressure Reference:	Gauge (default); Absolute reference input by user	
Standard Pressure Ranges (bar):	-1 to 2.5 bar; 0-16 bar; 0-100 bar; 0-400 bar; 0-1000 bar; 0-1500 bar; 0-2000 bar; 0-4000 bar; 0-5000 bar	
Standard Pressure Ranges (other):	User selectable for psi and other measurement units	
Overpressure Safety:	2x up to 400 bar; 1.5x for 1000 bar; 1.1x for 1500 bar; 1.5x for 2000 bar; 1.25x for 4000 bar; 1.2x for 5000 bar	
Load driving Capability:	4-20 mA: $RL < [UB - 13 V] / 20 \text{ mA}$; (e.g. with supply voltage (UB) of 36V, max. load (RL) is 1150 Ω); 10 mV/V: n/a; 0-5 V: max. load $RL > 5 \text{ K}\Omega$; 0-10 V: max. load $RL > 10 \text{ K}\Omega$	
Accuracy NLHR:	Ranges to 3000 bar: $\leq \pm 0.15 \%$ of span BFSL	Ranges above 3000 bar: $\leq \pm 0.35 \%$ of span BFSL
Sample Rate:	User selectable to 1000 samples per second (1000 Hz) Resolution: 21 bits for $\leq 5 \text{ Hz}$; 16 bits for $> 5 - 1000 \text{ Hz}$	
Operating Ambient Temperature:	-20 °C to +85 °C (-4 °F to +185 °F)	
Operating Media Temperature:	-50 °C to +125 °C (-58 °F to +257 °F)	
Storage Temperature:	+5 °C to +40 °C (+41 °F to +104°F) Recommended Best Practice	
Temperature Effects:	$\pm 1.5 \%$ FS total error band for -10 °C to +80 °C. Typical thermal zero and span coefficients $\pm 0.015 \%$ FS/ °C	
Electromagnetic Compatibility:	EN61326-1, EN61326-2-3 (Laboratory equipment)	
Wetted Parts:	Titanium alloy	
Pressure Media:	All fluids compatible with titanium alloy	
Pressure Connection:	1/4" BSP male (G1/4); 1/4" NPT male, F250-C (Autoclave) or or M16 x 1.5 female cone seal	
Electrical Connection:	Standard version supplied with USB mini B to USB A 2m cable Heavy Duty version supplied with MIL-C-26482 (6 pin) to USB A 2m cable	
Software Compatibility:	Windows 8 8.1 10 11	
Net. Weight (Kg):	0.15 Kg	

Order Matrix

Output	Type	Electrical Connection	Pressure Range	Process Connection
Dynamic (1000 Hz)	GD4200			
Electrical Connection				
USB Mini B		HUSB		
MIL-C-26482 (6 pin)		HBUSB		
Pressure Range				
-1 to 2.5 bar			02.5	
0-16 bar			0016	
0-100 bar			0100	
0-400 bar			0400	
0-1000 bar			1000	
0-1500 bar			1500	
0-2000 bar			2000	
0-3000 bar			3000	
0-4000 bar			4000	
0-5000 bar			5000	
Process Connection				
1/4" BSP male (G1/4)				AB
1/4" NPT male				AM
Autoclave F250-C female (for pressures above 1500 bar)				DE
M16 x 1.5 female cone seal				FK

Order Number Example GD4200HUSB1500AB

For options not listed please contact the sales team

DISCLAIMER : ESI Technology Ltd operates a policy of continuous product development. We reserve the right to change specification without prior notice. All products manufactured by ESI Technology Ltd are calibrated using precision calibration equipment, traceable to national measurement standards.